

## Register 17 CONTENS - AMP3



For further information  
Please contact CRP  
Tel. 01706 756 400  
Fax. 01706 379 567  
Web. [www.crp.co.uk](http://www.crp.co.uk)  
email. [enquiry@crp.co.uk](mailto:enquiry@crp.co.uk)

### Contents

	<b>Page</b>
<i>Technical Data AMP3-DIN</i> .....	2
<i>Technical Data AMP3-ANSI</i> .....	3
<i>Material Specification AMP3</i> .....	4
<i>Assembly Instruction AMP3</i> .....	5
<i>Disassembly Instruction AMP3</i> .....	6
<i>AMP3 - Recommended Tightening Torques</i> .....	7
<i>AMP3 with lockable hand lever</i> .....	8
<i>Switchsymbols AMP3 L</i> .....	9
<i>Switchsymbols AMP3 T</i> .....	10
<i>AMP3 - <math>K_v</math> and <math>C_v</math> - Data</i> .....	12

**Technical Data AMP3 - DIN**

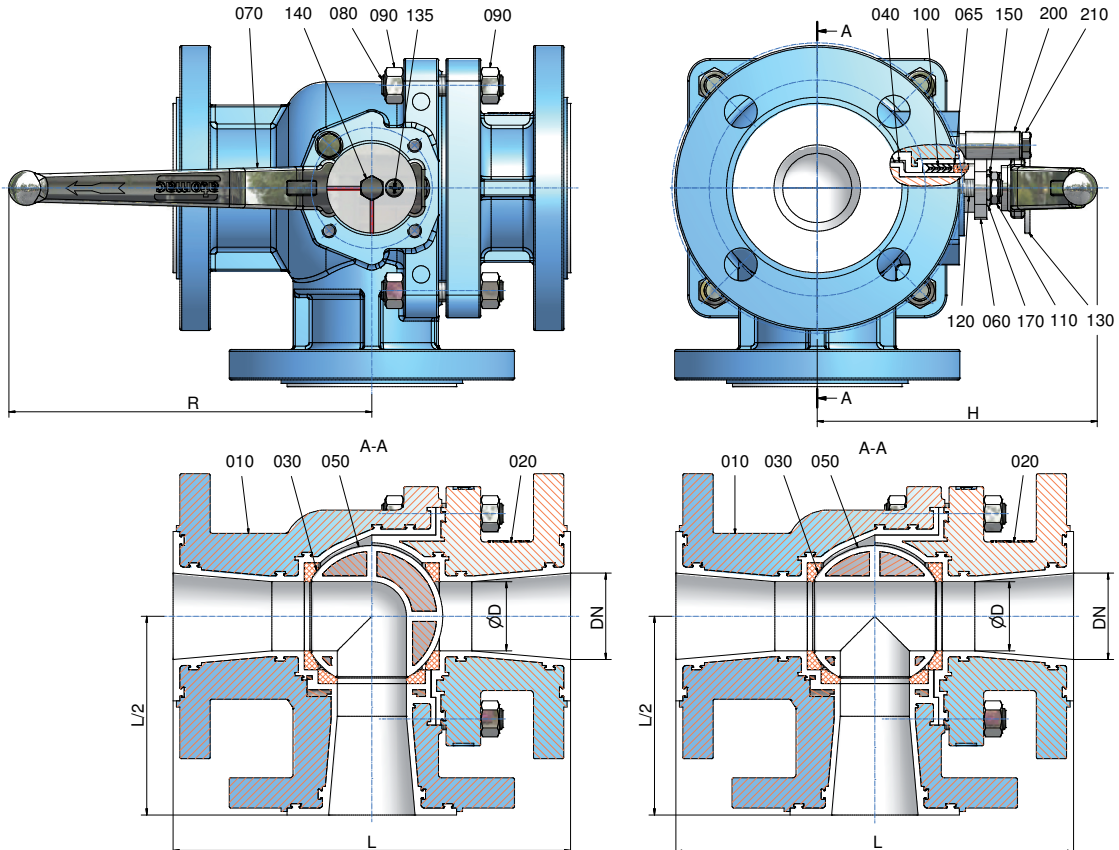

**L - Ball**

**T - Ball**

Face to Face dimensions: DIN EN 558  
 (Basic series 1)  
 Flange Connection: DIN EN 1092-2

DN / DIN		L	L/2	ØD	R	H	weight	
<b>025</b>	mm	160	80	20	160	125	kg	5,2
	inch	6,3	3,15	0,79	6,3	4,92	lbs	11,5
<b>040</b>	mm	200	100	32	210	149	kg	12,0
	inch	7,87	3,94	1,26	8,27	5,87	lbs	26,4
<b>050</b>	mm	230	115	40	210	165	kg	16,7
	inch	9,06	4,53	1,57	8,27	6,5	lbs	36,8
<b>080</b>	mm	310	155	60	313	200	kg	32,0
	inch	12,2	6,1	2,36	12,32	7,87	lbs	70,5
<b>100</b>	mm	350	175	75	313	220	kg	45,0
	inch	13,78	6,89	2,95	12,32	8,66	lbs	99,2
<b>150</b>	mm	480	240	128	674	313,5	kg	136,5
	inch	18,9	9,45	5,04	26,54	12,34	lbs	300,8

**Technical Data AMP3 - ANSI**

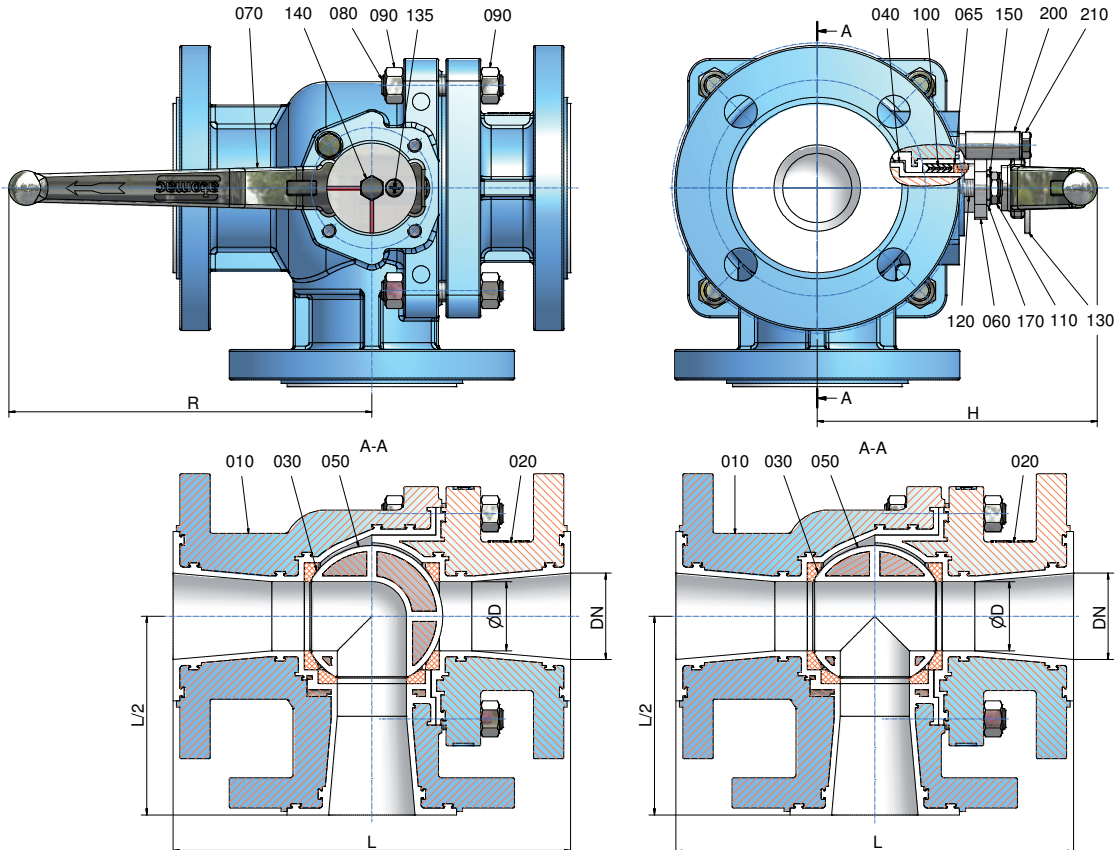

**L - Ball**

**T - Ball**

Face to Face dimensions: DIN EN 558  
 (Basic series 1)  
 Flange Connection: ANSI B 16.5

DN / ANSI		L	L/2	ØD	R	H	weight	
1"	mm	160	80	20	160	125	kg	5,2
	inch	6,3	3,15	0,79	6,3	4,92	lbs	11,5
1½"	mm	200	100	32	210	149	kg	12,0
	inch	7,87	3,94	1,26	8,27	5,87	lbs	26,4
2"	mm	230	115	40	210	165	kg	16,7
	inch	9,06	4,53	1,57	8,27	6,50	lbs	36,8
3"	mm	310	155	60	313	200	kg	32,0
	inch	12,2	6,1	2,36	12,32	7,87	lbs	70,5
4"	mm	350	175	75	313	220	kg	45,0
	inch	13,78	6,89	2,95	12,32	8,7	lbs	99,2
6"	mm	480	240	128	674	313,5	kg	137,7
	inch	18,9	9,45	5,04	26,54	12,34	lbs	303,5

## Material Specification AMP3

No.	Designation	Pieces	Material	Material-No. / DIN	ASTM / AISI
010	body	1	ductile iron / PFA ° ductile iron / FEP °	EN-JS1049 (GGG-40.3) / DIN EN 1563	A 395
020	side piece	1	ductile iron / PFA ° ductile iron / FEP °	EN-JS1049 (GGG-40.3) / DIN EN 1563	A 395
030	seat ring	3	PTFE	pure - PTFE	
040	stem	1	stainless steel / PFA	1.4470 / DIN EN 10283	A 890 CD3MN
050	ball	1	ductile iron / PFA ° ductile iron / FEP °	EN-JS1049 (GGG-40.3) / DIN EN 1563	A 395
060	gland follower	1	stainless steel	1.4308 / DIN EN 10283	A 743 CF-8
065	gland insert	1	PTFE-graphite		
070	hand lever				
	DN 1" - 2", DN 25 - 50	1	die cast metall (galvanized)	ZP0410 / DIN EN 12844	
	DN 3" -4", DN 080 - 100	1	ductile iron (galvanized)	EN-GJS-50-7 (GGG-50)	
	DN 6", DN 150	1	steel (galvanized)	1.0037 / DIN EN 10025-2	A 283 B
080	stud bolt	1 set	stainless steel	1.4301 / DIN EN 10088-3	A 193 B8
090	hexagon nut	1 set	stainless steel	1.4301 / DIN EN 10088-3	A 193 B8
100	packing material (chevron)	1 set	PTFE		
110	hexagon nut	2	stainless steel	1.4301 / DIN EN 10088-3	A 194 8
120	stud bolt	2	stainless steel	1.4301 / DIN EN 10088-3	A 193 B8
130	locking position indicator	1	stainless steel	1.4301 / DIN EN 10088-3	AISI 304
135	countersunk screw	1	stainless steel	1.4301 / DIN EN 10088-3	A 193 B8
140	hexagon bolt	1	stainless steel	1.4301 / DIN EN 10088-3	A 193 B8
150	serrated lock washer	2	stainless steel	1.4301 / DIN EN 10088-3	AISI 304
170	grounding device	1	stainless steel	1.4310 / DIN EN 10270-3	AISI 301
200	stop				
	DN 1", 1½", 2", 3", DN 080, 100	1	steel (galvanized)	1.0037 / DIN EN 10025-2	A 283 B
	DN 2", 6", DN 025 - 050, 150	1	steel (galvanized)	1.0037 / DIN EN 10025-2	A 283 B
		1	stainless steel	1.4104 / DIN EN 10088-3	AISI 430 F
		1	stainless steel	1.4104 / DIN EN 10088-3	AISI 430 F
210	hexagon bolt	1	stainless steel	1.4301 / DIN EN 10088-3	A 193 B8

° optional

## Assembly Instruction AMP3

The general installation and maintenance instructions must be observed.

1. Screw stud bolts (120) into body (010).
2. Insert the stem (040) from inside of the body in such a way that the flat side is parallel to the body longitudinal axis.
3. Insert the chevron packing (100).
4. Install gland insert (065), gland follower (060) including the insert (065) as well as the safety washers (150), hexagon nuts (110) and the grounding strap (170). Use the grounding strap also when the valve will be automated or mounted with a gear.
5. Install hand lever (070) on the stem (040) and tighten it using the position indicator (130) and hexagon bolt (140).
6. Fasten the position indicator (130) on the hand lever with the countersunk bolt (135).
7. Insert the lower ball seat ring (030) into the body (010).
8. Together with the second ball seat ring (030) insert the L- or T-ball (050) into the body. The stem flats fit the ball flats. Pay attention to which switching symbol is required (see separate switching symbol charts).
9. Turn the ball (050) in that way that the closed side of the ball will show to the side piece connection.
10. Screw stud bolts (080) into side piece (020).
11. Place the third ball seat ring (030) on the ball (050) and install the side piece. Take care of the right position of the recess for the ball seat ring in the body.
12. Screw the hexagon nuts (090) on the stud bolts (080) and tighten them by crisscross method to recommended torques.
13. According to the configuration of the valve install either one or two stops (200) by using the hexagon bolts (210).

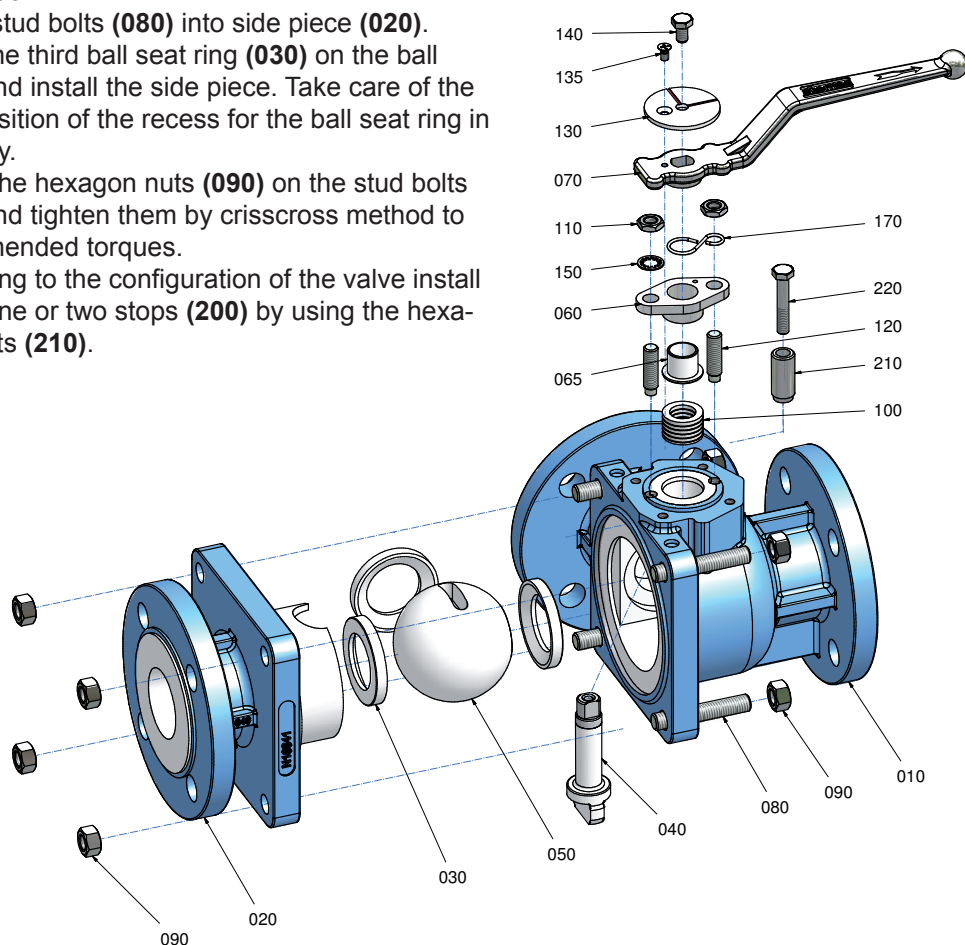

## Disassembly Instruction AMP3

For all jobs which are to be carried out on an installed valve, the works safety requirements and the general accident prevention instructions must be observed. Moreover, the general installation and maintenance instructions for atomac fluorcarbon resin lined valves must be considered.

1. Prior to disassembly, the valve must be cleared of all fluid according to the above mentioned instructions. Particular care must be taken that during rinsing and draining of the piping, the valve is opened and closed repeatedly. These cycles (opening and closing) are to be repeated during draining of the piping. Only when following this procedure, it is ensured that all remaining pressure inside the body (stem guide and ball seats) is eliminated.
2. For disassembly of the valve put it on a work bench with a soft cover (rubber mat). Remove hexagon nuts (110) and lock washer (150).
3. Disassemble the hand lever (070) with the position indicator (130) by removing the hexagon bolt (140).
4. Remove grounding device (170), gland insert (065) and packing gland follower (060). If necessary stud bolts (120) can also be removed now.
5. Unscrew the hexagon nuts (090) and remove side piece (020) from the body (010).
6. Remove the ball seat ring (030) out of the side piece (020).
7. Including the ball seat ring (030) on side remove the ball (050) out of the body (010).
8. The lower ball seat ring (030) can easily be removed now out of the body.
9. Disassemble the stem (040) by pushing it down through the body (010). Care must be taken not to damage the body liner.
10. Chevron packing (100) can be removed.
11. If necessary, remove hand lever stop (s) (200) by removing the hexagon bolt (s) (210).

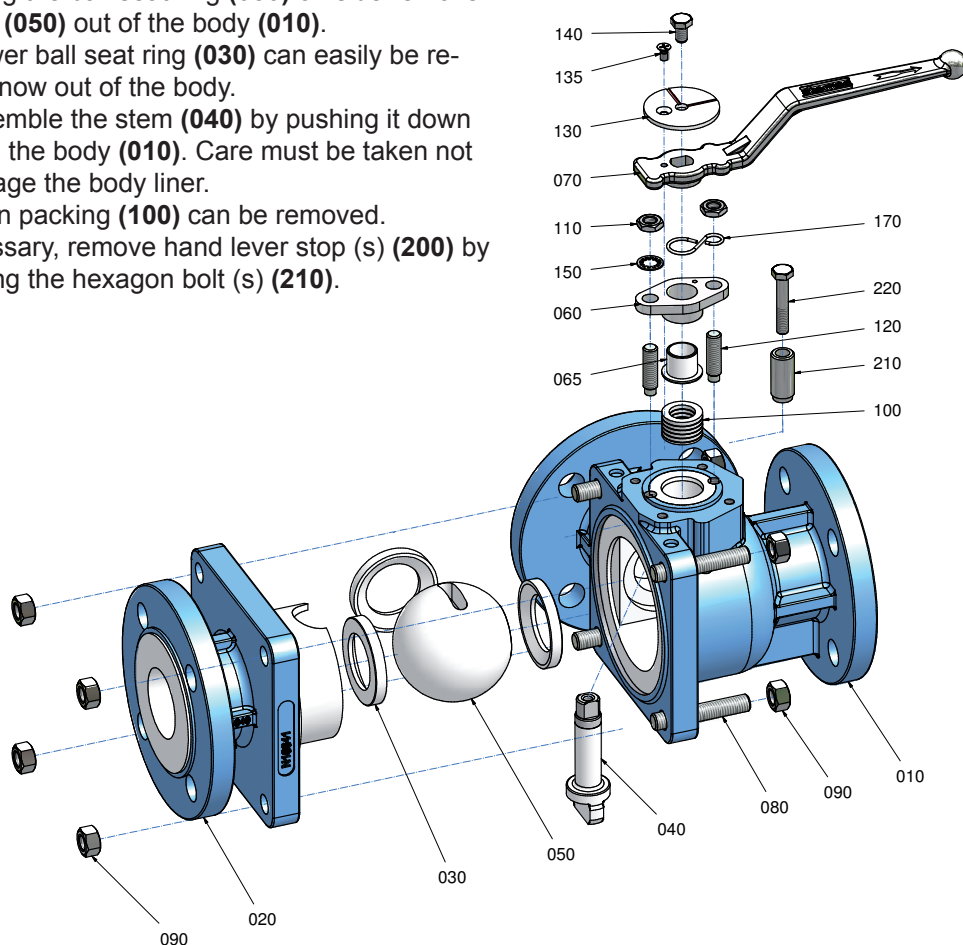

## AMP3 - Recommended Tightening Torques\*

DN	tie rods (080/090)		connection flange		gland bolts (110/120/150)	
	Nm	in.lbs	Nm	in.lbs	Nm	in.lbs
<b>025</b>	21	186	36	319	4	35
<b>1"</b>	14	124	17	150	4	35
<b>040</b>	49	434	75	664	7	62
<b>1½"</b>	52	460	39	345	7	62
<b>050</b>	70	620	95	841	7	62
<b>2"</b>	75	664	79	699	7	62
<b>080</b>	61	540	75	664	8	71
<b>3"</b>	65	575	129	1142	8	71
<b>100</b>	114	1009	87	770	8	71
<b>4"</b>	116	1027	97	858	8	71
<b>150</b>	153	1354	130	1151	12	106
<b>6"</b>	161	1425	129	1142	12	106

\* *maximum value*

**AMP3 with lockable hand lever**

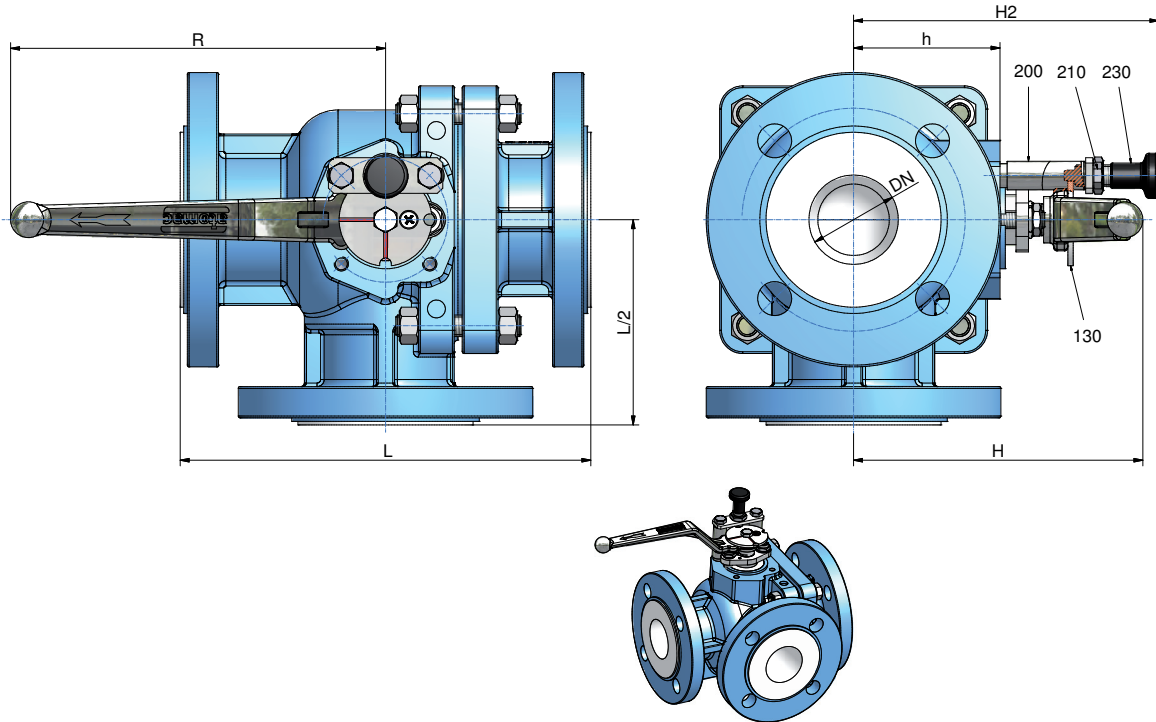

DIN	ANSI		L	L/2	H	R	H2	h
025	1"	mm	160	80	125	160	125	52
		inch	6,3	3,15	4,92	6,3	4,9	2
040	1½"	mm	200	100	149	210	158	72
		inch	7,87	3,94	5,87	8,27	6,22	2,83
050	2"	mm	230	115	165	210	163	82
		inch	9,06	4,53	6,5	8,27	6,42	3,23
080	3"	mm	310	155	200	313	230	119
		inch	12,2	6,10	7,87	12,32	9,06	4,69
100	4"	mm	350	175	220	313	242	132
		inch	13,78	6,89	8,66	12,32	9,53	5,2
150	6"	mm	480	240	314	674	335	204
		inch	18,9	9,45	12,34	26,54	13,19	8,03

No.	Designation	Pieces	Material	Material-No.	DIN	ASTM / AISI
130	locking position indicator	1	stainless steel	1.4301	DIN 17440	AISI 304
200	stop	1	stainless steel	1.4301	DIN 17440	AISI 430F
210	hexagon bolt	1	stainless steel	1.4301	DIN 17440	A 193 B8
230	locking bolt	1	stainless steell / duroplastic	1.4301	DIN 17440	AISI 304



### Switchsymbols AMP3L

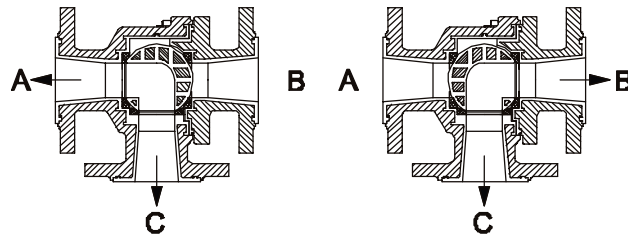
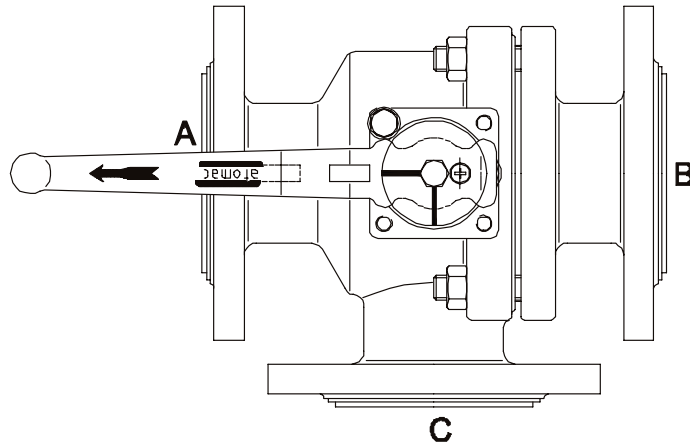

**symbol No.1 - 90° switch**

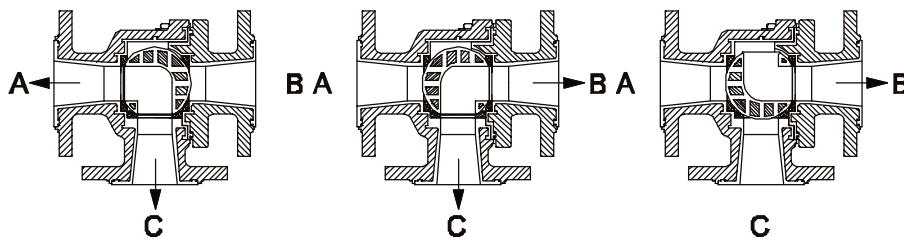

**symbol No.1.1 - 180° switch**

**Switchsymbols AMP3T**

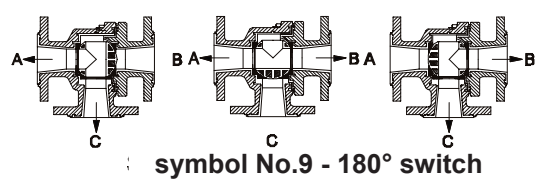
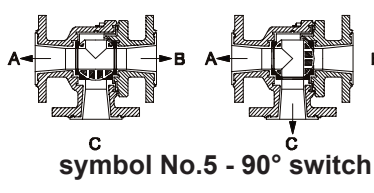
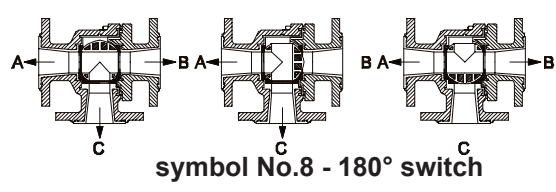
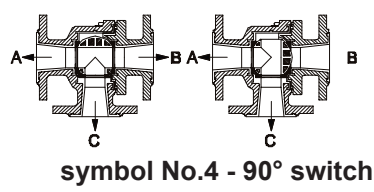
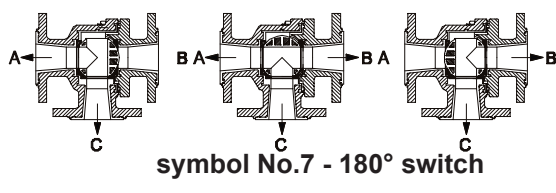
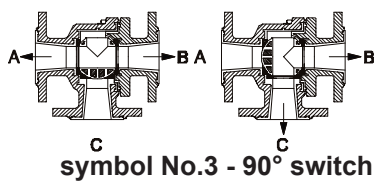
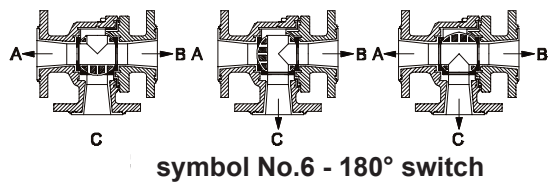
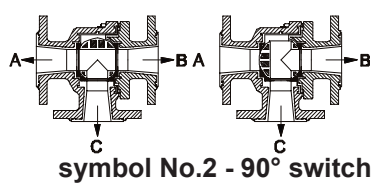
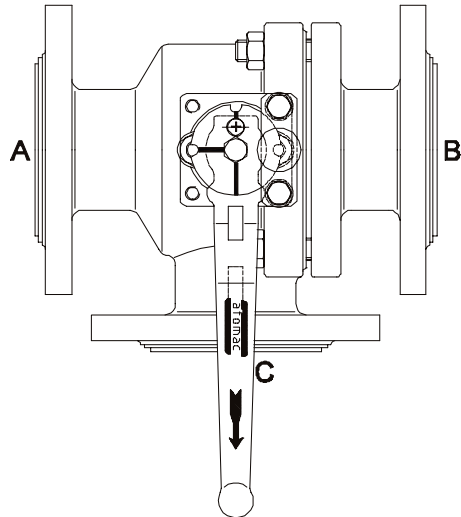

**AMP3 -  $K_v$  Werte and  $C_v$  Data  
 (DIN EN 60534-2-3)**

<b>AMP3 L A → C (B → C)</b>			
ANSI	DIN	$K_v$ m <sup>3</sup> /h	$C_v$ gal/min
1"	025	11,9	13,8
1 1/2"	040	31,4	36,5
2"	050	51,6	60,0
3"	080	107,0	124,4
4"	100	190,7	221,7
6"	150	- at the moment not available -	

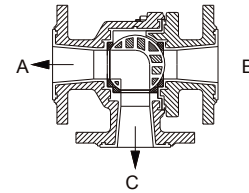

<b>AMP3 T A → B</b>			
ANSI	DIN	$K_v$ m <sup>3</sup> /h	$C_v$ gal/min
1"	025	24,9	28,9
1 1/2"	040	80,2	93,2
2"	050	129,0	149,9
3"	080	292,6	340,1
4"	100	572,3	665,2
6"	150	- at the moment not available -	

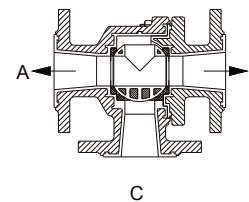

<b>AMP3 T A → C (B → C)</b>			
ANSI	DIN	$K_v$ m <sup>3</sup> /h	$C_v$ gal/min
1"	025	9,4	10,9
1 1/2"	040	32,1	37,3
2"	050	53,5	62,2
3"	080	108,4	126,0
4"	100	177,5	206,3
6"	150	- at the moment not available -	

